

CALANDRE CU USCARE INDUSTRIALE CU CILINDRU INCALZIT

I
GAMA

I 80	IR 80	IF 80	IFF 80
800MM	800MM	800MM	800MM



DESIGN ROBUST



HIGH OUTPUT



SYSTEM
MODULAR

DISPOZITIV DE IMPACHETARE RUFEE



DISPOZITIV DE STOCARE RUFEE CALCATE



CARACTERISTICI

- Suprafata mare de contact cu rufele
- Protectie pentru degete si buton de oprire de siguranta pentru mai multa securitate
- Racire automata
- Microprocesor usor de utilizat tip MCX
- Ventilator supradimensionat pentru o instalare flexibila
- Indicarea vitezei si temperaturii de calcare
- Posibilitatea accesarii modului revers (deplasarea benzilor de calcare in sens invers)
- Posibilitatea amplasarii cu spatele langa perete pentru economie de spatiu: returul rufelor in fata

- Motor controlat prin modificarea frecventei
- Incalzire electrica, cu gaz sau cu abur
- OCS – Sistem de verificarea supraincalzirii
- IR80 – Calandru cu iesirea rufelor calcate prin fata si prin spate
- IF80 – Calandru cu modul R cu plierea lenjeriei pe lungime
- IFF80 – calandru cu dispozitiv de alimentare si de pliere lenjerie pe lungime

OPTIUNI

- Pedala de oprire
- Masa cu absorbtie (vacuum)
- CS – dispozitive de impachetare si stoacre a lenjeriei calcate

TIP CALANDRU		I80			IR80			IF80			IFF80		
		E	G	S	E	G	S	E	G	S	E	G	S
DIAMETRUL ROLEI	mm	800			800			800			800		
LUNGIMEA UTILA A ROLEI	mm	3186			3186			3186			3186		
PUTERE													
Incalzire	kW (E,G) kg/h (S)	75	103*	190	75	103*	190	75	103*	190	75	103*	190
MOTOR ACTIONARE ROLA	kW	0,9			1,15			1,25			2		
MOTOR VENTILATOR	kW (50/60Hz)	2x0,55/0,75			2x0,55/0,75			2x0,55/0,75			2x0,55/0,75		
PRODUCTIVITATE**	kg	195			195			195			195		
VITEZA ROLA CALCARE	m/min.	3-15			3-15			3-15 (3-8 cu pliere pe lungime)			3-15 (3-8 cu pliere pe lungime)		
CAPACITATE VENTILATOR	m ³ /h	2x1300			2x1300			2x1300			2x1300		
RACORD ELECTRIC		380-415V 3AC+N 50/60 Hz 208-240V 3AC 50/60 Hz 380-415V 3AC-N 50/60 Hz 440-480V 3AC 60 Hz											
DIMENSIUNI HxLxA	mm	1985x4260x1915			1985x4260x1915			1985x4260x1915			1985x4260x1915		
Greutate neta	kg	2610	2480	2900	2860	2730	3150	2970	2840	3260	3170	3040	3460
DIMENSIUNI AMBALAJ													
HxLxA	mm	2080x4380x2080			2080x4380x2080			2080x4380x2080			2080x4380x2080		
Greutate bruta	kg	2870	2740	3160	3120	2990	3410	3230	3100	3520	3430	3300	3720

* G20, 20 mbar

** In conformitate cu standardul ISO 9398-1

Versiunea standard

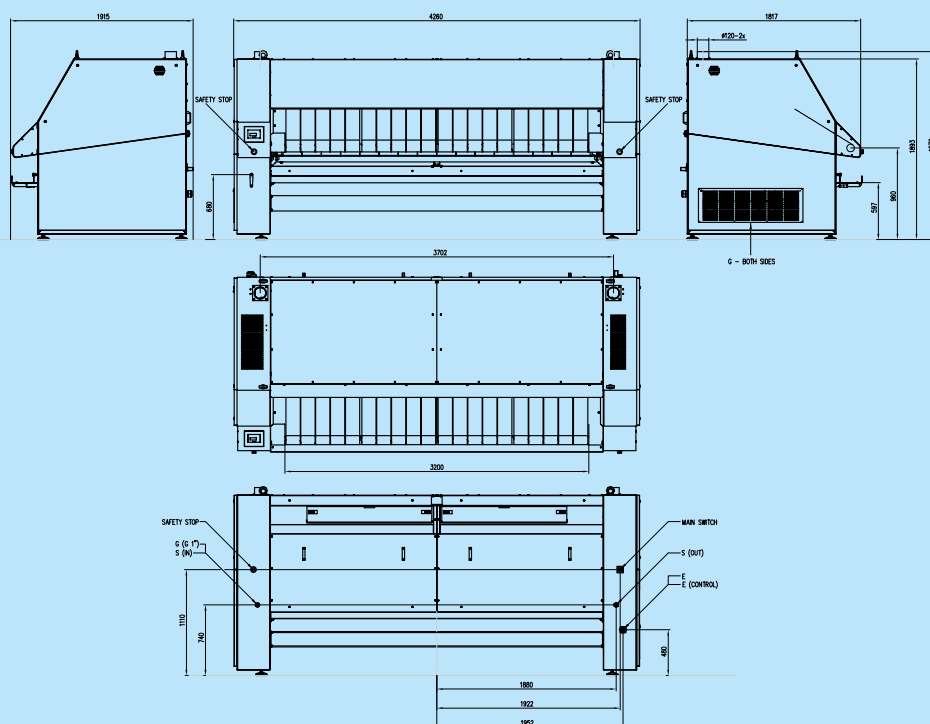

The Primus preserves the right to change the machines and the specification in this leaflet at any time, without prior notice. Details and photographs are only for information and never binding.

www.primuslaundry.com

Primus by Alliance Laundry Systems



12-2017